



Aluminium IP.66 | Valve Position Monitor



Exd flameproof

Type SRA coated hard anodised aluminium valve position monitor dual Certified ATEX / IECEx II 2 GD / Ex d IIB+H2 T6 providing a system ideally suited for zone 1 & 2 hazardous area locations typically found in the onshore process industries. The IP66 enclosure has a bolt-on cover and top mounted high visibility open / close position indicator.



Powder coated hard anodised aluminium enclosure for superior corrosion protection.

ATEX / IECEx Certified II 2 GD / Ex d IIB+H2 T6 flameproof for zone 1 & 2 hazardous areas.

Ingress protection IP66 to protect internal electrical components from the harshest environments.

Available with 2 x M20 conduit entries as standard (M25 & NPT versions are optional).

Switch / sensor terminations via. European approved terminal blocks.

Different electrical switch / sensor functions available including mechanical, reed proximity and inductive proximity.

Continuous feedback versions available with 4 to 20mA non-contact and programmable HART transmitters.

Bus communication versions available On Request including AS-Interface, DeviceNet, Foundation Fieldbus and Modbus protocols.

Touch and tune quick setting cams allow for fast and simple switch / sensor adjustments.

Compact design with bolt-on cover and top mounted high visibility open / close position indicator.

As standard, supplied with F05 mounting holes & Namur drive shaft to suit VDI/VDE.3845 topworks actuators (bracket required).

Special mounting kits available to suit non-standard topworks quarter-turn and linear stroke actuators.

Ex marking:
II 2 GD
Ex d IIB+H2 T4/T6 Gb
Ex tb IIIC T130°C / T85°C Db
T_{amb} = -50°C to +60°C T6 & -50°C to +85°C T4

Certificate Number:
TRAC12ATEX0050X
IECEx TRC 12.0022X



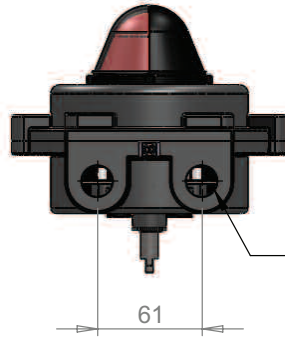

(2) M20 Conduit Entry
(Other Sizes on Request)

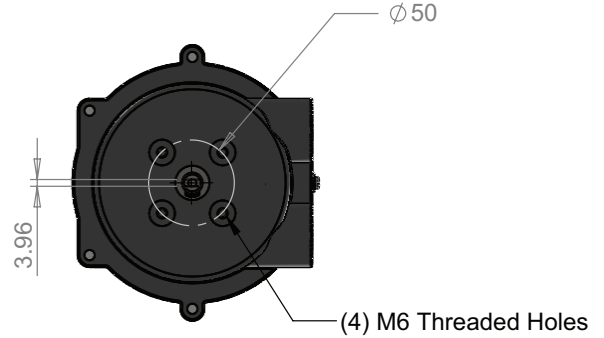
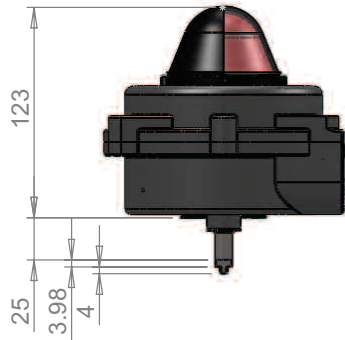
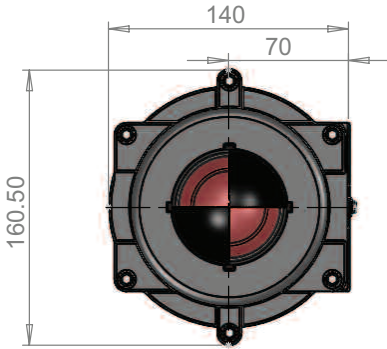
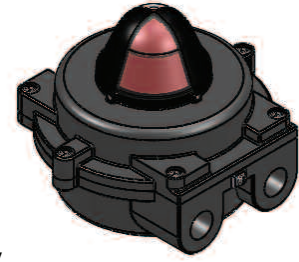

Note: Output Drive shaft dimension shown is for Code 'M' Namur 25mm. Please contact Technical Sales for Code 'L' and Code 'S' options.

Imtex Controls Limited is constantly improving the specifications, design and production of its products and alterations take place continually. Whilst every effort is made to produce up to date literature this leaflet should not be regarded as an inflexible guide to current specifications. E & OE.

Aluminium IP.66 | Valve Position Monitor

www.imtex-controls.com/sra

Model Number Compilation (Drawing No. A190280)

Type	Electrical Function	Material of Construction	Conduit Size	Output Drive	Visual Indicator	Feature
SRA	16	9	5	M	R	100

Code	Electrical Function - Standard Options ¹
14	(2) DPDT Mechanical Switches
16 / 55	(2) / (4) SPDT Mechanical Switches
17 / 56	(2) / (4) SPDT Mechanical Switches 'GP' Contacts
25 / 58	(2) / (4) SPDT Reed Proximity Switches
40 / 59	(2) / (4) SPST Reed Proximity Switches
42 / 52	(2) / (4) V3 Inductive Proximity Sensors
43 / 53	(2) / (4) Other Inductive Proximity Sensors
70	4 to 20mA Transmitter (Non-contact)
Material of Construction (Enclosure)	
9	Aluminium (Anodised) Coated
Conduit Size	
5	(2) M20 x 1.5
8	(2) NPT - 1 x 3/8" / 1 x 1/2"
B	(2) NPT - 2 x 1/2"
D	(2) M25 x 1.5
E	(2) 1 x M25 / 1 x M20

Code	Output Drive
L	Namur 15mm
M	Namur 25mm
S	2-pin Coupler
Visual Indicator*	
R	Red (Closed) / Green (Open)
B	Blue (Closed) / White (Open)
E	Red (Closed) / Yellow (Open)
W	Red (Closed) / White (Open)
Y	Dark Blue (Closed) / Yellow (Open)
0	No Visual Indicator
*ABS material	
Feature	
lxx	Dual ATEX / IECEx Ex d IIB+H2 T6 Certified
'xx'	See Note ²

NOTES

- Other Electrical Functions are available 'On Request'.
- The exact detail of electrical function fitted or any other special feature is not fully specified by the basic model code, therefore, the Feature Designator provides a mechanism for cross referencing to a centralised engineering log which identifies the detailed specification of the parts fitted in the given unit.
- Please refer to our Product Overview leaflet for full specification of the Electrical Functions provided or consult our Technical Sales.
- The maximum permitted power that can be dissipated within a specific model is specified on Drawing No.A160189 and the electrical characteristics and ratings of the components fitted must not allow this value to be exceeded.