

GENERAL DESCRIPTION / APPLICATIONS / DIMENSIONS (millimeters)

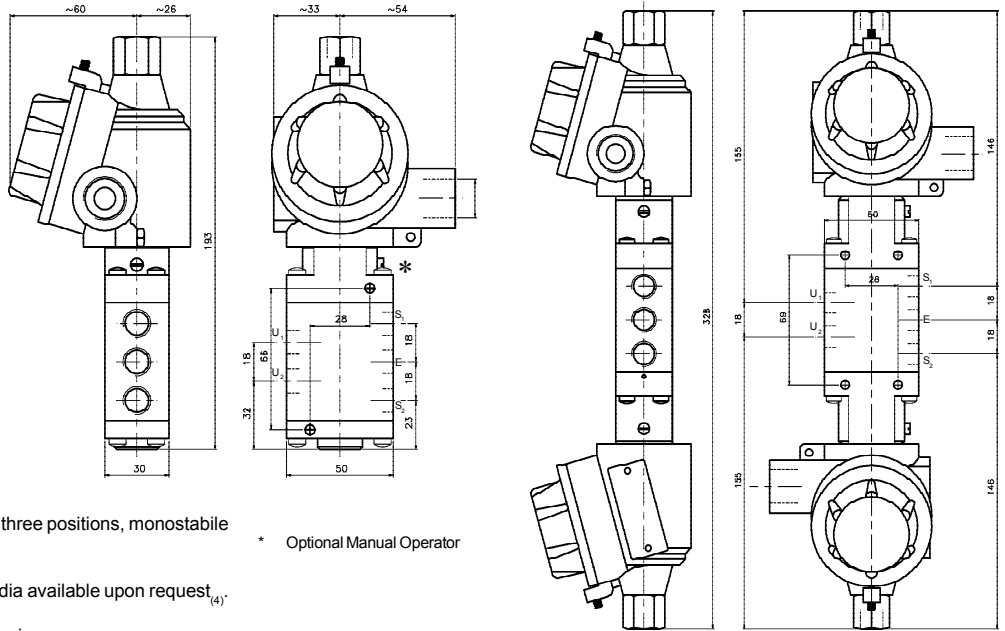
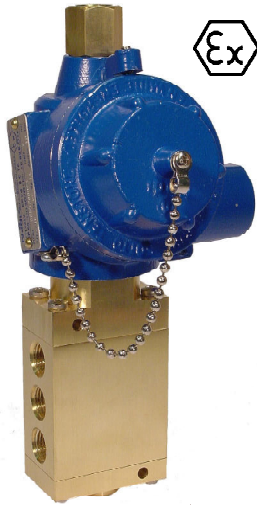

Five way solenoid valve, pilot operated, two and three positions, monostable or bistable.

Suitable for gaseous media. Model for liquid media available upon request⁽⁴⁾.

Stainless steel internal parts. Stainless steel spring.

Stainless steel internal parts. Stainless steel springs. 360° degrees orientable solenoid. Mountable in any position.

* Optional Manual Operator

ELECTRICAL SPECIFICATIONS

Light alloy explosion-proof “Ex-d” (EN60079-1) solenoid housing. Electrical and mechanical parts certified according to 2014/34/UE (“ATEX”) directive, suitable to control the flow of inert and/or flammable gases or liquids. Internal and external anti-twist ground connecting screws. Inside terminal board suitable for cable up to 2,5 mm².

- cable entry threaded: 1/2" Gk UNI-6125 (standard)
1/2" NPT, ISO M20x1.5 (available upon request)
- protection class: IP-67
- Ex protection class: Ex-d II 1G/2GDc (IIB o IIC)
- Temperature class: T6 or T5 (t.amb -20 ÷ +40 °C)
T5 or T4 (t.amb -20 ÷ +60 °C) upon request.
T5 or T4 (t.amb -60 ÷ +60 °C) upon request⁽¹⁾
- Coil insulation class: F (155°C) - H (180°C) upon request.
- Winding wire class: H (180°C)
- Duty: Continuous (S.I.) 100% ED
- Power consumption: Alternate current 11VA (inrush 28VA).
Direct current 11W.
- Tolleranza tensione: ± 10% (standard) others available upon request
- Voltage tolerance: ± 10%
- Insulation: >1000 MOhm
- Dielectrical Strength: >2000 V/1'
- Standard voltages 12, 24, 48, 110, 115, 125, 220, 240 Volt
- DC=₍₂₎ o AC~(50/60Hz): other voltages available upon request.

OPERATION

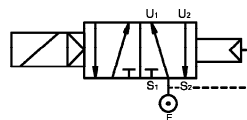

D03.D - Single solenoid Monostable

- In: E
- Coil de-energized: from E to U1.
from U2 to S2.
- Coil energized: from E to U2.
from U1 to S1.

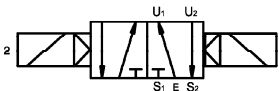

D05.D - Double solenoid Bistable

- In: E
- Coil 1 energized: from E to U1.
from U2 to S2.
- Coil 2 energized: from E to U2.
from U1 to S1
- Coils de-energized: Latched on the last position.

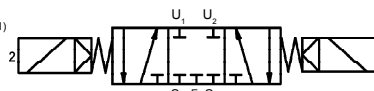

D07.D - Double solenoid Bistable, closed centers.

- In: E
- Coil 1 energized: from E to U1.
from U2 to S2.
- Coil 2 energized: from E to U2.
from U1 to S1
- Coils de-energized: E, U1, U2, S1, S2 closed

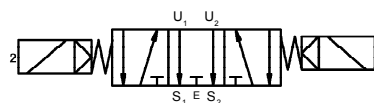

D09.D - Double solenoid Bistable, open centers.

- In: E
- Coil 1 energized: from E to U1.
from U2 to S2.
- Coil 2 energized: from E to U2.
from U1 to S1
- Coils de-energized: from U1 to S1
from U2 to S2

SPECIFICATIONS AND AVAILABLE OPTIONS

MODEL	ORIFICE DIAMETER mm					BODY RATING	PRESSURES IN BAR ⁽³⁾			Flow factor kv (liters/min.')	WEIGHT Kg.	
							MIN./MAX. OPERATING DIFFERENTIAL PRESSURE					
							MIN.	MAX. AC~	MAX. DC=			
D 0 3	a	b	c	d	e	7	10	3	10	10	12.5	1.2
D 0 5	7	0				7	10	3	10	10	12.5	1.5
D 0 7	7	0				7	10	3	10	10	12.5	1.5
D 0 9	7	0				7	10	3	10	10	12.5	1.5

suffix (options available upon request): ⁽¹⁾ "LT" (low t.amb. certificate), ⁽²⁾ "V" (spike suppressor), ⁽³⁾ "AP" (High pressure version)- ⁽⁴⁾ "H2O" (for water).

a	b	c	d	e
Body material	Port size	Seals material	Protection class	Optional features
T Brass. N Nickel-plated brass. I Stainless steel.	C 1/4" GAS D 1/4" NPT	0 Buna N 1 FPM 7 HNBR	B Ex-d IIB C Ex-d IIC	X Stable Manual operator.

Le caratteristiche possono subire variazioni senza preavviso / Characteristics may change without notice.